

If you are a man who thrives on the drive and excitement of today's executive world, if you are a man who takes for granted what other men think exceptional—Imperial '67 was made for you.

Because you never neglect the comfort of others . . . the passenger seat of both two-door models glides forward at a nudge on the seat back to widen the rear seat entryway. The seats are styled after those found in executive aircraft. They are swathed with leather and

garnished with nylon fur trim. Because you expect superior performance . . . Imperial '67 is an exceptional road car.

The engine is now—440 cubic inches. And behind the engine is a newly engineered automatic transmission. The dual braking system is standard. Discs in the front, drums in the rear. A new warning light monitors the brakes.

The suspension is new. Rubber isolates the passenger compartment from vibration. Handling is quick. Capable.

Since a contemporary luxury car must live up to the life you lead, Imperial's styling is new.

The convertible top, for example, Sewille-grain vinyl which mounts flush to retain Imperial's unadorned silhouette. The new Tomcat fasteners are concealed. They cannot obscure the Imperial's poise. The new convertible rear window is, of course,

If you are a little bored by the pre-hailed luxury cues, you should stop by your Imperial Dealer's. He has some new ideas to show you.

The 1967 Imperial Crown Convertible in Cinnamon Gold Metallic

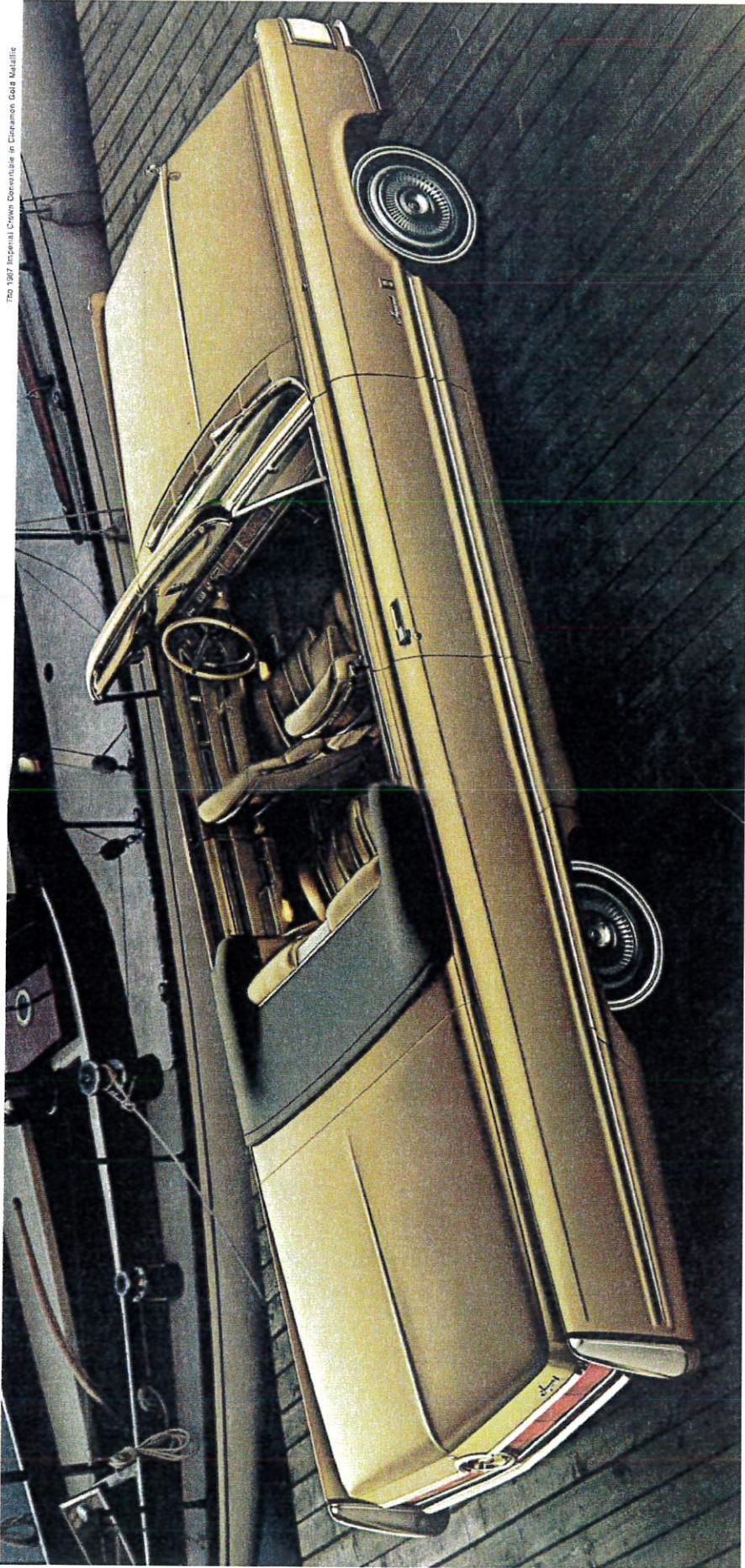

The policy of Chrysler Corporation is one of continual improvement in design and manufacture wherever possible to insure a still finer car. Hence, specifications, equipment and prices are subject to change without notice. Although in some cases, show optional equipment, available at extra cost.

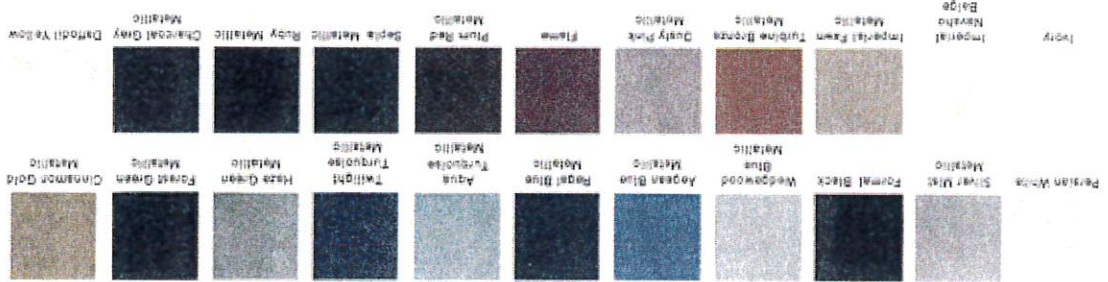

Standard equipment includes: Auxiliary clock Remote control outside mirror Underswinging Wheel covers Ram hood Automatic hood Motor bumper seats with leather upholstery Nylon fur trim (with leather only) Retainable Automatic transmission Power steering and brakes Power windows Very hot Rear window defogger Rear window defogger (California only)

Optional equipment includes: Auxiliary clock Remote control outside mirror Underswinging Wheel covers Ram hood Automatic hood Motor bumper seats with leather upholstery Nylon fur trim (with leather only) Retainable Automatic transmission Power steering and brakes Power windows Very hot Rear window defogger Rear window defogger (California only)

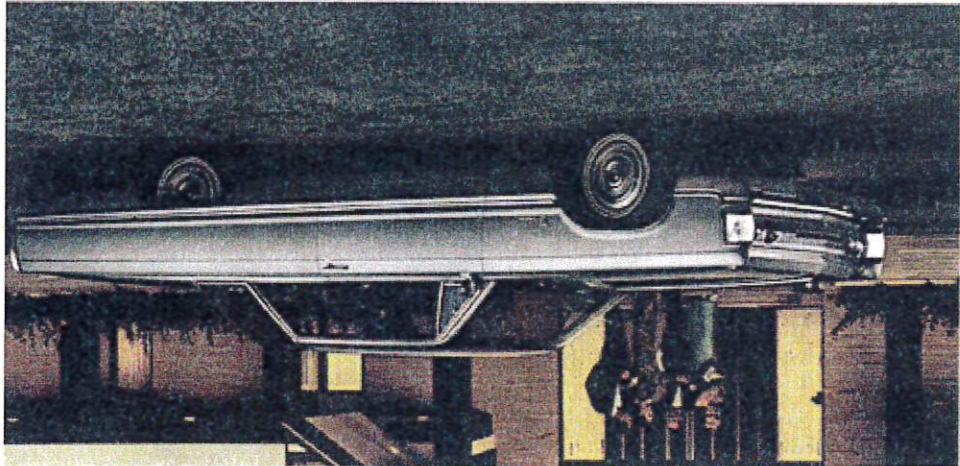

The Imperial Crown Four-Door Hardtop
 Standard equipment includes: Automatic transmission Power steering and brakes Power windows Rear-side warning markers Retainable vinyl top Rear-door carpeting Two hand center armrests Dual hand center armrests Remote car center mirror Electric clock Remote car center mirror Four glove compartments Four glove compartments Vandy wiper mirror Four cigarette holders and ashtrays 50/50 split rear seat with passenger and driver side reclining Wheel covers Retainable Underswinging Wheel covers Ram hood Automatic hood Motor bumper seats with leather upholstery Nylon fur trim (with leather only) Retainable Automatic transmission Power steering and brakes Power windows Very hot Rear window defogger Rear window defogger (California only)



In the Crown Convertible, rear seat passengers have a door stretcher.

If you are a man who thrives on the
drive and excitement of today's ex-
cursive world, if you are a man who
takes for granted what other men
think exceptional—Imperial '67 was
made for you.
Because you never neglect the
comfort of others . . . the passenger
seat of both two-door models glides
forward at a nudge on the seat back
to widen the rear seat entryway.
The seats are styled after those
found in exclusive aircraft. They
are swathed with leather and
garnished with nylon fur trim.
Because you expect superior per-
formance . . . Imperial '67 is an excep-
tional road car.
The engine is new—440 cubic inches.
And behind the engine is a newly
engineered automatic transmission.
The dual braking system is
standard. Discs in the front, drums
in the rear. A new warning light
monitors the brakes.
The suspension is new. Rubber lac-
lates the passenger compartment from
vibration. Handling is quick. Capable.

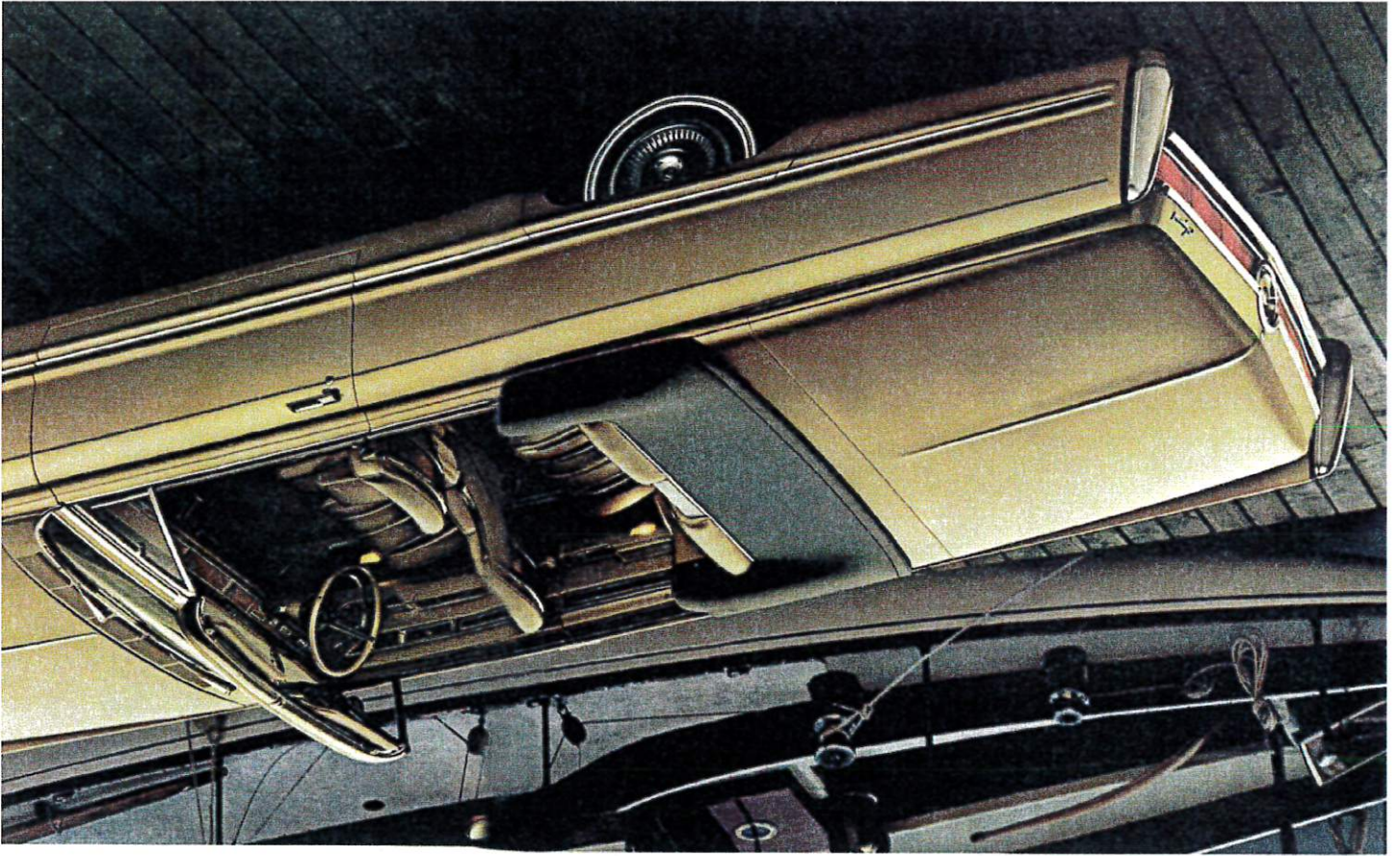

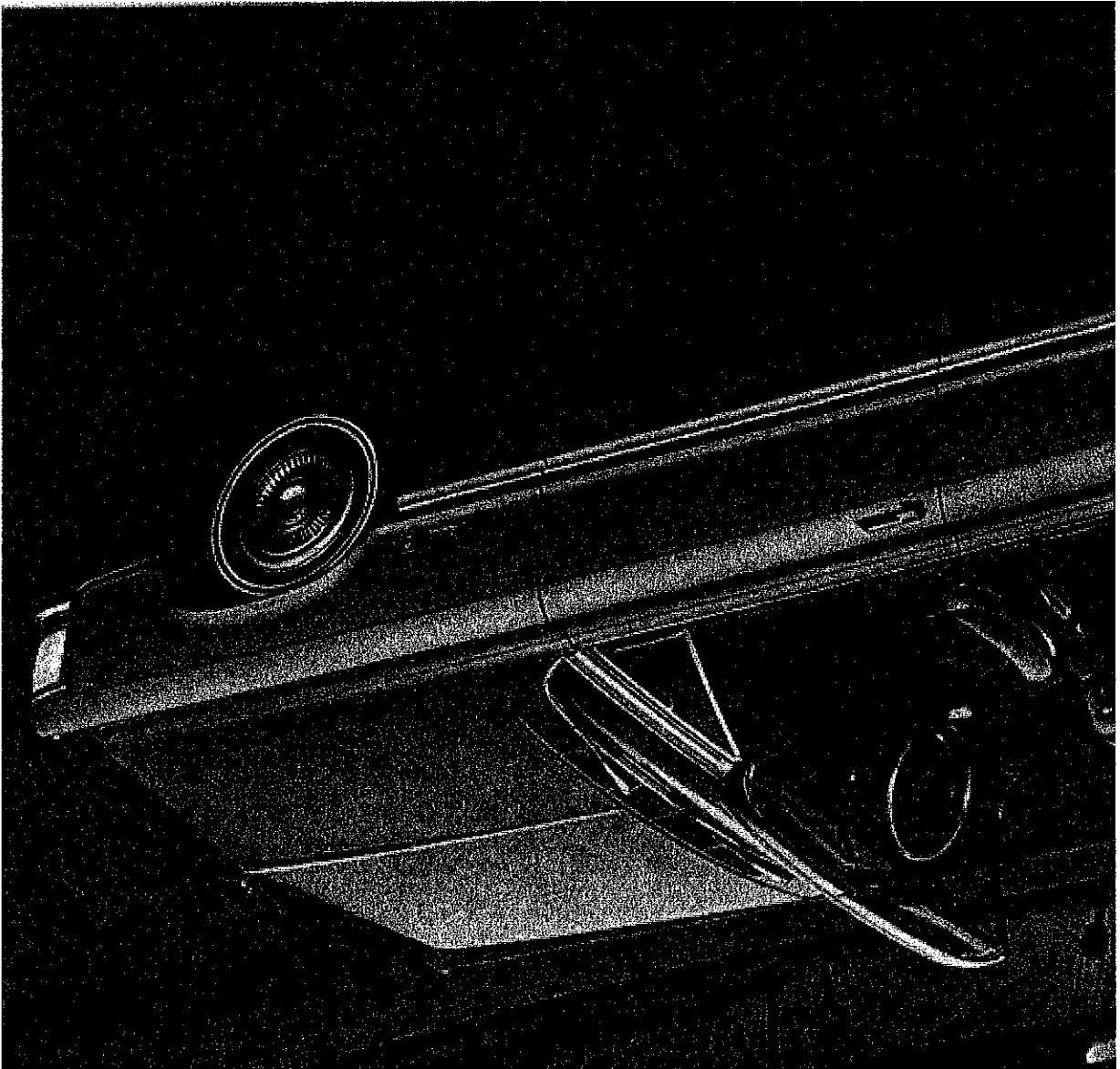

The 1967 Imperial Crown Convertible in Geneva, Switzerland

If you are a man who believes on the drive and excitement of today's exclusive world, if you are a man who takes for granted what other men think exceptional--Imperial '67 was made for you.

Because you never neglect the comfort of others... the passenger seat of both two-door models glides forward at a nudge on the seat back. The seats are styled after those found in executive aircraft. They are swathed with leather and

garnished with nylon fur trim. Because you expect superior performance... Imperial '67 is an unequal landl' road car.

The engine is now--440 cubic inches. And behind the engine is a newly engineered automatic transmission. The dual braking system is standard. Discs in the front, drums in the rear. A new warning light monitors the brakes.

The suspension is new. Rubber boots the passenger compartment from vibration. Handling is quick. Capable.

Since a contemporary luxury car must live up to the life you lead, Imperial's styling is new.

The convertible top, for example, must live up to the life you lead. To retain Imperial's unruffled silhouette. The new Toronado leatherette concealed. They cannot disturb the Imperial's poise. The new convertible rear window is glass.

If you are a little bored by the gray-haired luxury cars, you should stop by your Imperial Dealer. He has some new ideas to show you.

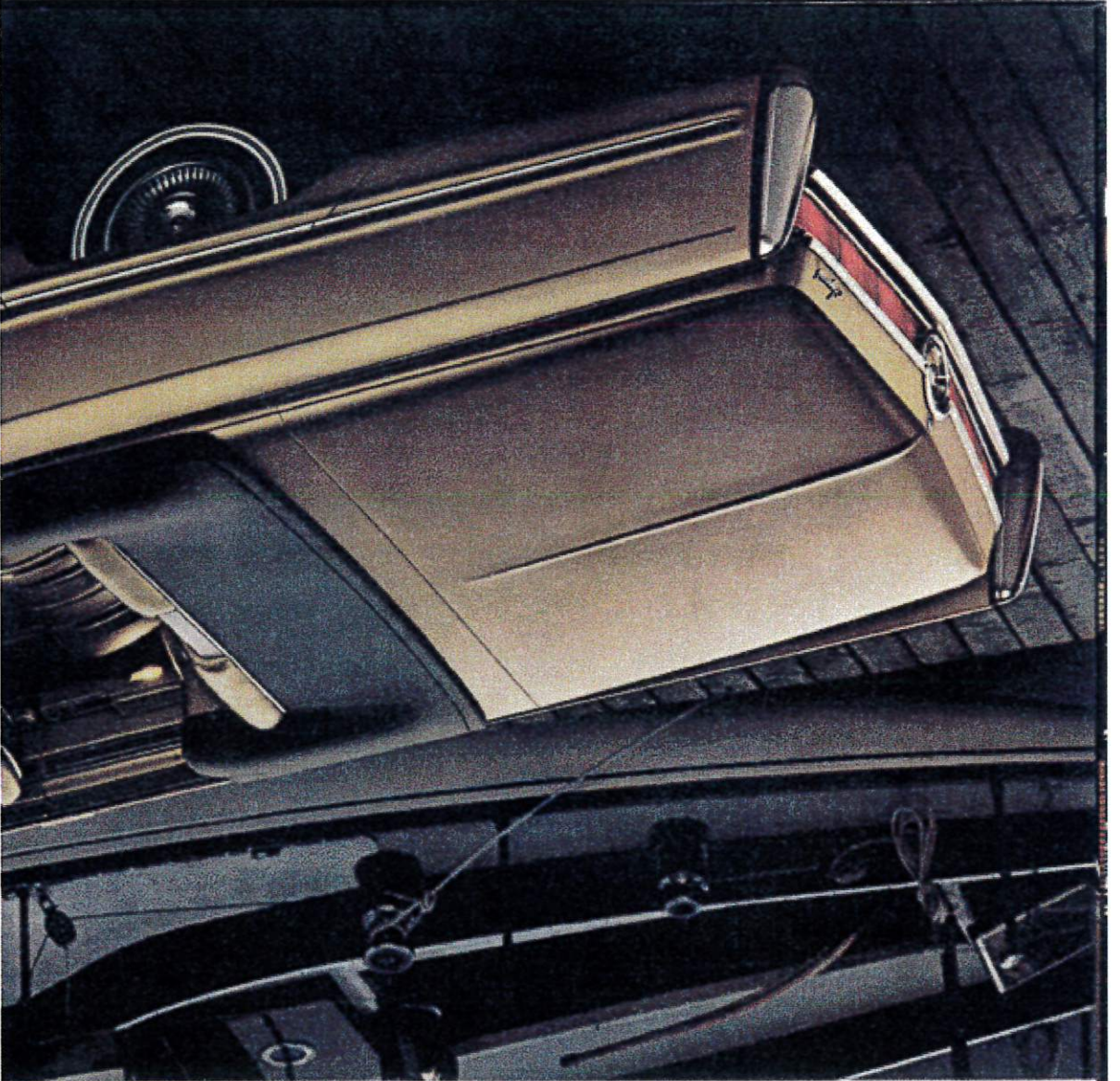

In the Crown Convertible, rear seat passengers have a door stretcher.

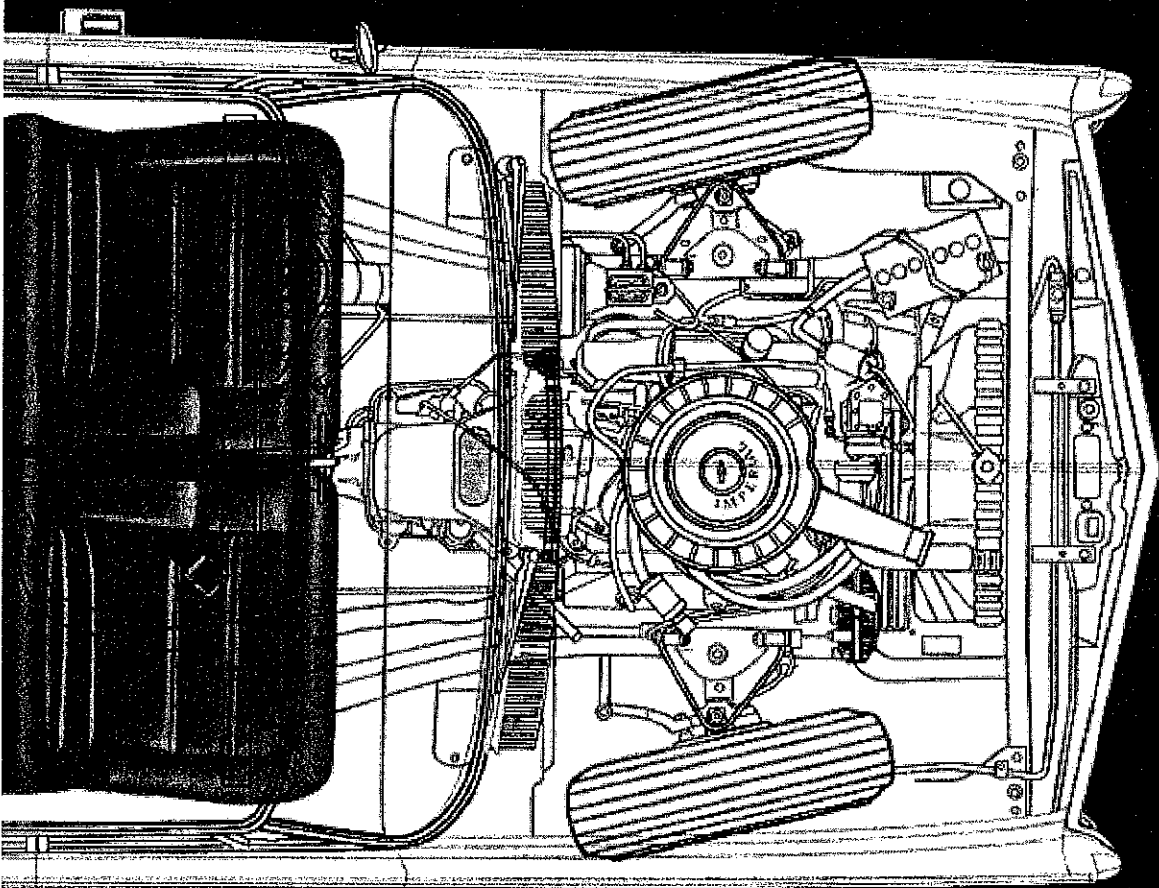

Fuel System: 4-barrel carburetor with mechanically controlled secondary barrels. Automatic choke. Positive throttle return. Fuel tank capacity 25 gallons.

Engine: Overhead valve 90 degree V8, 440 cu. in. displacement, 10.1 to 1 compression ratio. 350 hp @ 4400 rpm, Torque, 480 ft. lbs. @ 2800 rpm.

Electrical system: 12-volt battery; 78 plates; 70 amp. hr. rating; 37-amp alternator (60-amp with air conditioning).

Frame: Unit construction body, with isolated front structural system.

Steering: Full-time power steering, 3.5 turns, full left to full right, symmetrical later-arm steering linkage, hydraulic and mechanical steering reaction systems, Energy-absorbing steering column.

Transmissions: Torqueflite automatic with column-mounted detector lever, 3-speed planetary gear set with torque converter, Transmission breakaway ratio, 5.9 to 1 overall.

Here's how Imparata's year/50,000-mile engine and drive train warranty protects you: Chrysler Corporation warrants, for 5 years or 50,000 miles, whichever comes first, against defects in materials and workmanship and will replace or repair at an authorized Imparata (or Chrysler, Plymouth, or Dodge) Dealer's place of business, without charge for required parts and labor, the engine block, head and internal parts, torque converter, water pump, fans, mission case and internal parts, torque converter drive shaft, universal joints, rear axle and differential, and rear wheel bearings of its 1987 Imparata 4-cylinder, provided the owner has the engine oil changed every 3 months or 4,000 miles, whichever comes first, the oil filter replaced every 3 months or 4,000 miles, and the carburetor air filter cleaned every 6 months and replaced every 2 years, and every 6 months, whichever is such a dealer or evidence of performance of the required service, and requests the dealer to certify (1) receipt of such evidence and (2) the car's then current mileage.

Imperial's new 440 cubic inch V8 is the largest automobile engine ever offered by Chrysler Corporation.

Dimensions: For closed models—wheelbase, 127 in. Front tread, 62.4 in.; Rear, 61.1 in. (loaded) 55.2 in., except convertible at 56.1 in. Overall length 224.7 in. Width, 79.6 in. Height

Suspension: Chrome-steel torsion bar, independent front wheel suspension. Ball-joint pivots. Hotchkiss drive, 62 in. rubber-isolated leaf-type rear springs, mounted 45 in. apart. Off-load shock absorbers at all four wheels. Rear track bar.

Brakes: Disc brakes standard front. Drum rear. Dual master-cylinder. Swopling area 437 sq. in. Mechanical parking brake with automatic release.

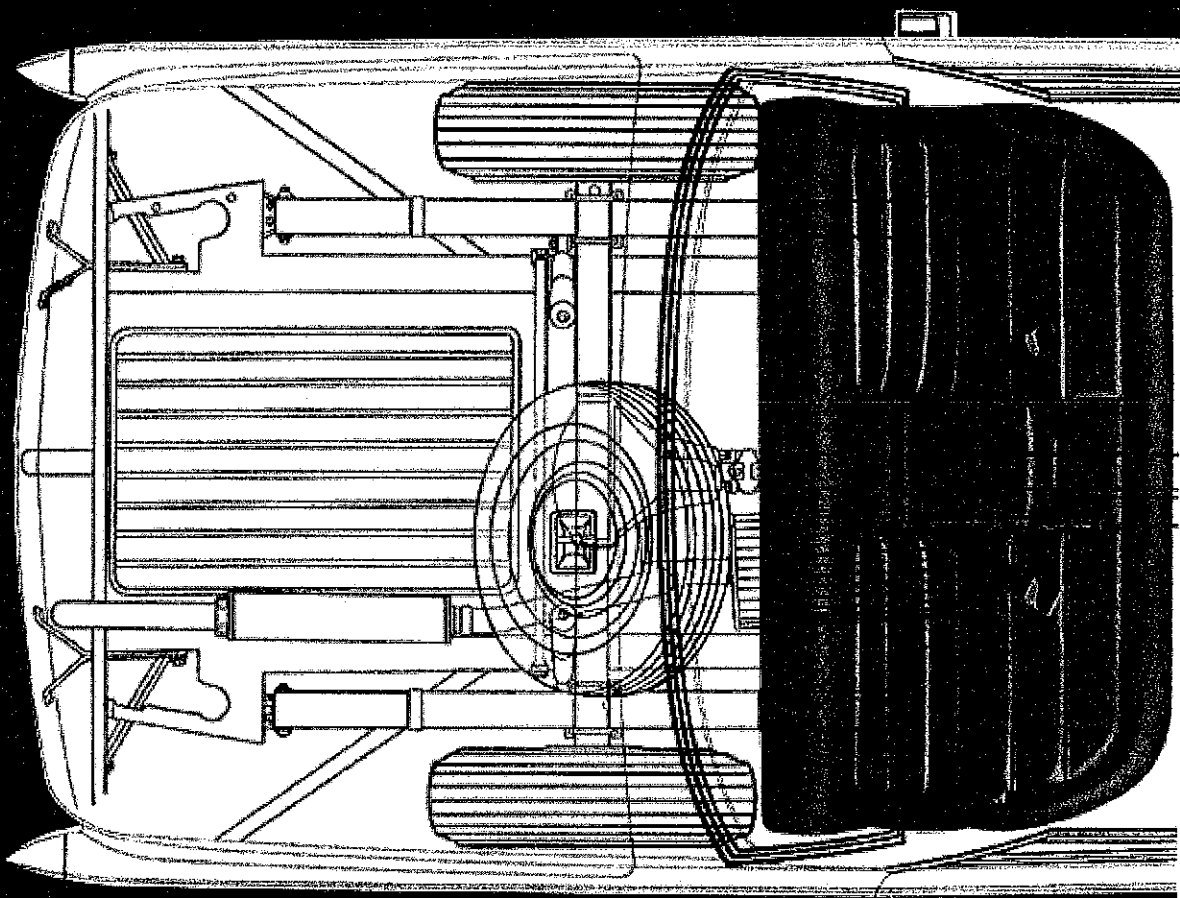

Wheels and Tires: Low profile tubelless, 9.15 x 15. Safety-Rim wheels. Stainless steel wheel covers with die cast applique.
Recommended Power Train Option: The Sure-Grip differential which automatically transfers power to the rear wheel with traction when the other rear wheel is slipping.
Interior Dimensions: Head room front, 39.4 in.; Rear, 38.6 in.; Leg room front, 42.0 in.; Rear, 39.8 in.; Shoulder room, front and rear, 60.0 in.; Knee room, 6.5 in. (Dimensions for Imperial Sedan only. May vary slightly with other models.)
For those owners who tow a trailer, a special equipment package is available. See your dealer for details.

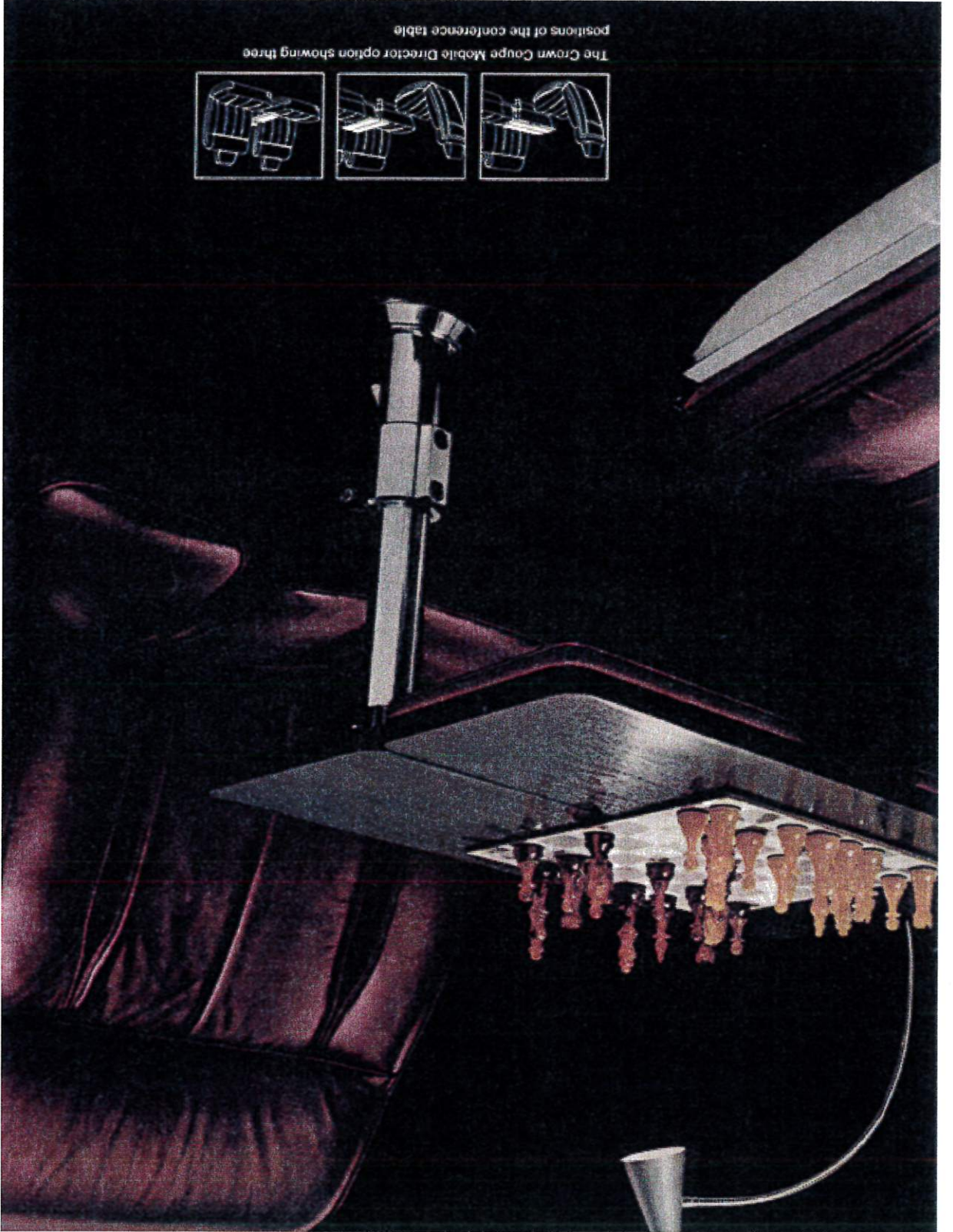

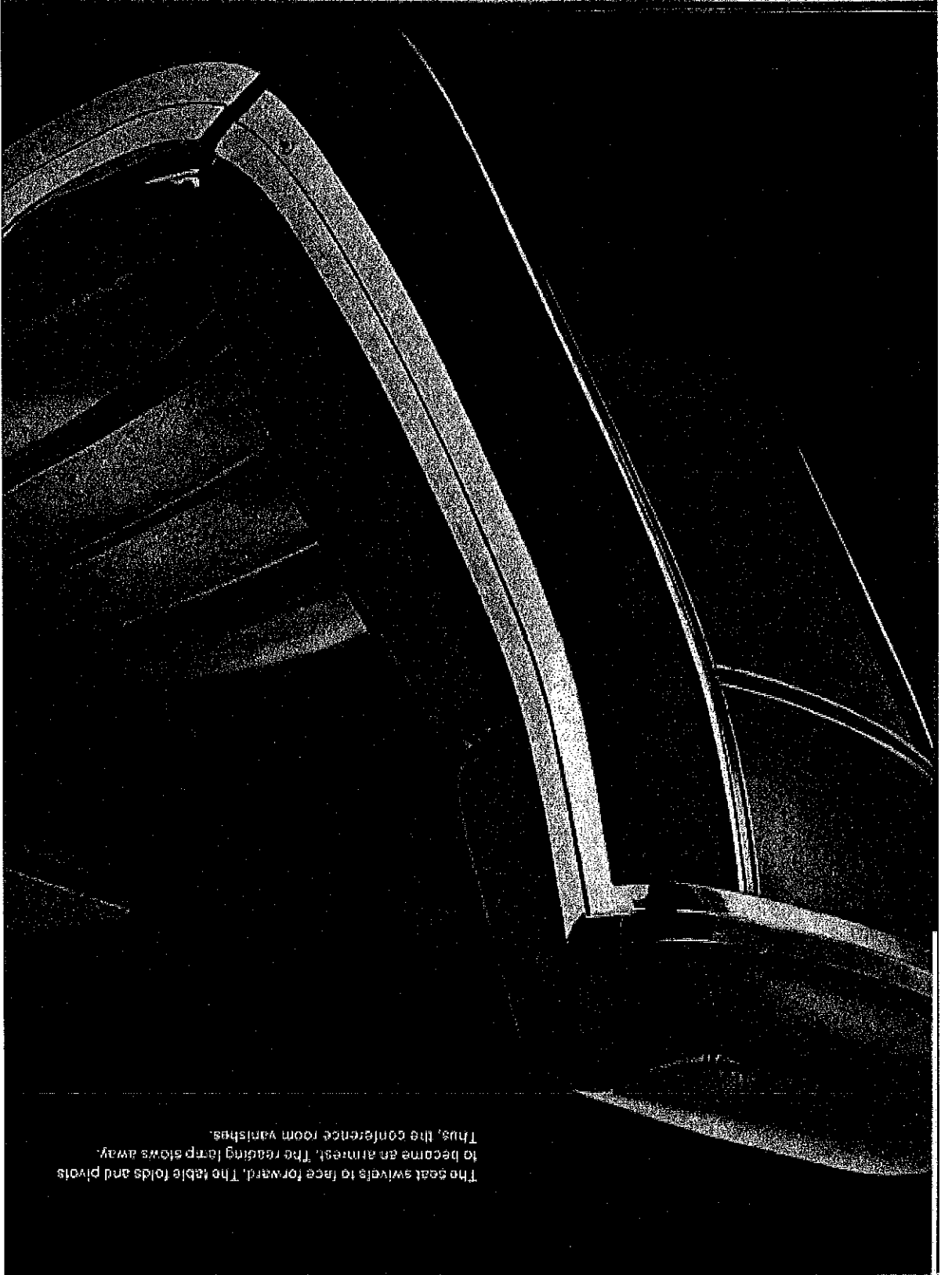

The seat swivels to face forward. The table folds and pivots to become an armrest. The reading lamp stays away. Thus, the conference room vanishes.